

## TRAJECTORY TRACKING CONTROL FOR 4 WHEEL SKID-STEERING MOBILE ROBOT

Dang Van Nghin<sup>(1)</sup>, Nguyen Van Quoc Khanh<sup>(2)</sup>

(1) Ho Chi Minh Institute of Mechanics and Informatics

(2) University of Technology, VNU-HCM

(Manuscript Received on July 09<sup>th</sup>, 2009, Manuscript Revised December 29<sup>th</sup>, 2009)

**ABSTRACT:** By applying a nonholonomic constraints and Lagrange equation for nonholonomic system, a method is given to model and control the 4-wheel skid-steering mobile robot which tracks a given trajectory. First at all, a fundamental of nonholonomic system is introduced. Next, the skid steering robot's kinematic model and dynamic model are considered. To control the robot tracking a trajectory, a new algorithm is given by applying feedback linearization and PD control. In addition, simulation results show the good performance in tracking trajectories.

**Keywords:** tracking control, skid steering robot, nonholonomic constraints.

### 1. INTRODUCTION

The skid steering robot is considered as all-terrain vehicle, and has many advantages than other off-road robots, for example, a high maneuverability, high-power, an ability of

working in hard environmental conditions but the mechanism is quite simple. The following figure and table show major steering types and a steering system evaluation [1].

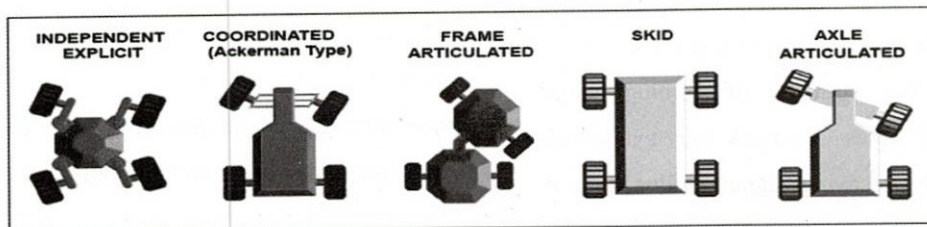

Fig. 1 Kinematics of major steering types

Table 1. A steering system evaluation

	Independent Explicit	Coordinated Ackerman	Frame Articulated	Skid	Axle Articulated
Maneuverability	med/high	med	med	high	med
Mechanical complexity	med	med/high	low	low	low
Control complexity	low	med/low	med	low	med/high
Power	med	med/low	med	high	low
Number of joints for steering	4	1	1	0	0

The skid steering robot is navigated by the angular velocity difference between left wheels and right wheels [2]. Because of lateral skidding, velocity constraints occurring in skid steering robot are quite different from the ones met in other mobile platforms wheels are not supposed to skid. An example for this steering type is ATRV-J robot designed by Irobot company.

Recently, Kozlowski et al. (2004) developed the skid steering robot's model based on Dixon's kinematic controller [3], [4], [5]. Kozlowski extended new time differentiable and time-varying control scheme based on the strategy of forcing some transformed states to track an exogenous exponentially decaying signal produced by a tunable oscillator [6], [7].

In this paper, a new control algorithm based on feedback linearization and PD control is presented. It allows us to control a reference point fixing in the 4 wheel skid steering mobile robot tracks a given trajectory. The first advantage of the algorithm is kinematics and dynamics can be studied separately. For

example, the angular velocity of each wheel can be determined without the inertia moment and the mass of the robot. Furthermore, this algorithm can be applied to not only the 4 wheel skid-steering mobile robot but also all types of the mobile robot whose equations of motion are similar to equation's Lagrange. Fields of application of the skid steering robot can be extended. For instance, the manipulator or GPR radar can be stuck on the robot to inspect the geology.

## 2. NONHOLONOMIC SYSTEM

Major wheeled mobile robot is a typical example of mechanical systems with nonholonomic constraints. Although navigation and planning of mobile robots have been investigated extensively over the past decade, the work on dynamic control of mobile robots with nonholonomic constraints is much more recent.

We consider mechanical systems that are subject to nonholonomic constraints characterized by the following equation:

$$A(q)\dot{q} = 0 \quad (1)$$

Where  $q$  is the  $n$ -dimensional generalized coordinates

$A(q)$  is an  $m \times n$  dimensional matrix

Because the constraints are assumed to be nonholonomic, (1) is not integrable. It will be assumed that these constraints are independent. In another words,  $A(q)$  has rank  $m$ .

Using the vector  $\lambda$  of Lagrange multiplier, the equations of motion of nonholonomically constrained systems are governed by:

$$M(q)\ddot{q} + V(q, \dot{q}) + G(q) = E(q)u + A^T(q)\lambda \quad (2)$$

Where:  $M(q)$  is the  $n \times n$  dimensional positive definite inertia matrix.

$V(q, \dot{q})$  is the  $n$  dimensional velocity-dependent force vector.

$G(q)$  is the gravitational force vector.

$u$  is the  $r$  dimensional vector of actuator force/torque

$E(q)$  is the  $n \times r$  dimensional matrix mapping the actuator space into the generalized coordinate.

It has been established that nonholonomic system described by the constraint equation (1) and the motion equation (2). [8]

### 3. MODEL OF A SKID STEERING MOBILE ROBOT

#### 3.1 Kinematic model

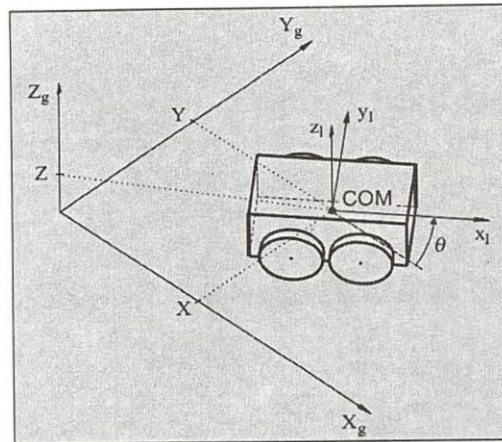

Fig. 2. The robot in the inertial frame

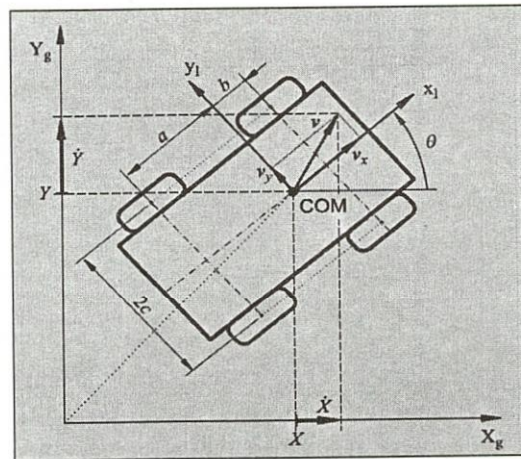

Fig. 3. Schematic of the skid steering robot.

The notation is shown in fig. 2, 3.

Select the inertial frame  $(COM^{x_1 y_1 z_1})$ , where COM is center of mass.

Let  $(X, Y, Z)$  to be robot's barycentric coordinates in the world frame,

$$v = \begin{bmatrix} v_x \\ v_y \\ 0 \end{bmatrix}, \quad \omega = \begin{bmatrix} 0 \\ 0 \\ \omega \end{bmatrix}, \quad q = \begin{bmatrix} X \\ Y \\ \theta \end{bmatrix}$$

Note:  $\omega = \dot{\theta}$



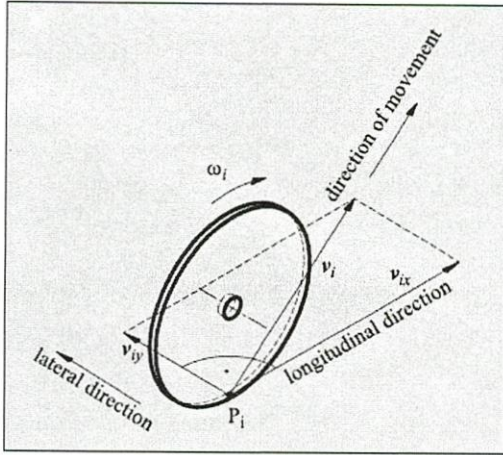

Fig. 4. Velocities of one wheel.

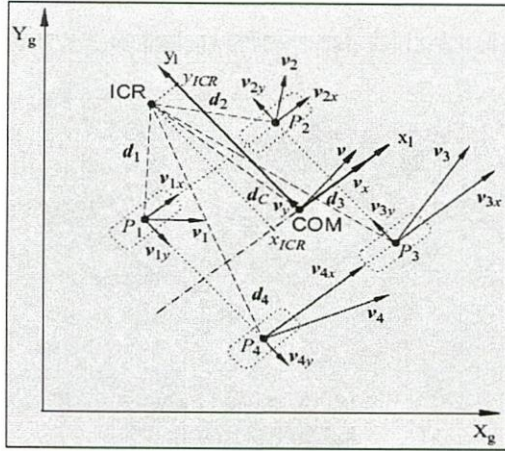

Fig. 5. Wheel velocities.

We have:

$$\begin{bmatrix} \dot{X} \\ \dot{Y} \end{bmatrix} = \begin{bmatrix} \cos \theta & -\sin \theta \\ \sin \theta & \cos \theta \end{bmatrix} \cdot \begin{bmatrix} v_x \\ v_y \end{bmatrix} \quad (3)$$

The  $i$ -th wheel rotates with an angular velocity  $\omega_i(t)$ , where  $i=1;2;3;4$ .

The longitudinal velocity can be obtained:

$$v_{ix} = r_{ix} \cdot \omega_i \quad (4)$$

In contrast to most wheeled mobile robot, the lateral velocity of the skid steering robot  $v_{iy}$  is generally nonzero.

The radius vector  $d_i = [d_{ix} \quad d_{iy}]^T$  and  $d_c = [d_{cx} \quad d_{cy}]^T$  are defined with respect to the local frame from the instantaneous center of rotation (IRC).

$$\text{Thus: } \frac{\|v_i\|}{\|d_i\|} = \frac{\|v\|}{\|d_c\|} = |\omega| \quad (5)$$

$$\frac{v_{ix}}{-d_{iy}} = \frac{v_x}{-d_{cy}} = \frac{v_{iy}}{d_{ix}} = \frac{v_y}{d_{cx}} = \omega \quad (6)$$

Coordinates of IRC in the local frames:

$$\text{ICR} (x_{irc}, y_{irc}) = (-d_{cx}, -d_{cy})$$

Writing (6) as follows:

$$\frac{v_x}{y_{irc}} = -\frac{v_y}{x_{irc}} = \omega \quad (7)$$

Otherwise, from the figure 4 we have:

$$\begin{aligned} d_{1y} &= d_{2y} = d_{cy} + c \\ d_{3y} &= d_{4y} = d_{cy} - c \\ d_{1x} &= d_{4x} = d_{cx} - a \\ d_{2x} &= d_{3x} = d_{cx} + b \end{aligned} \quad (8)$$

$$\text{Hence, } \begin{cases} v_L = v_{1x} = v_{2x} \\ v_R = v_{3x} = v_{4x} \\ v_F = v_{2y} = v_{3y} \\ v_B = v_{1y} = v_{4y} \end{cases} \quad (9)$$

$$\text{And, } \begin{bmatrix} v_L \\ v_R \\ v_F \\ v_B \end{bmatrix} = \begin{bmatrix} 1 & -c \\ 1 & c \\ 0 & -x_{irc} + b \\ 0 & -x_{irc} - a \end{bmatrix} \cdot \begin{bmatrix} v_x \\ \omega \end{bmatrix} \quad (10)$$

Assuming that  $r_1 = r_2 = r_3 = r_4 = r$

Because  $v_{1x} = v_{2x}$  and this is a skid-steering robot, the angular velocity of the first wheel equals the angular velocity of the second wheel.

So, let  $\omega_L$ ,  $\omega_R$  be respectively angular velocities of lefts and right wheels. We can write:

$$\begin{bmatrix} \omega_L \\ \omega_R \end{bmatrix} = \frac{1}{r} \begin{bmatrix} v_L \\ v_R \end{bmatrix} \quad (11)$$

Combining (10) and (11), a control input at kinematic level is defined as:

$$\eta = \begin{bmatrix} v_x \\ \omega \end{bmatrix} = r \cdot \begin{bmatrix} \frac{\omega_L + \omega_R}{2} \\ \frac{-\omega_L + \omega_R}{2.c} \end{bmatrix} \quad (12)$$

To complete the kinematic model, nonholonomic constraint is considered.

From (6), the velocity constraint characterized by:  $v_y + x_{irc} \cdot \dot{\theta} = 0$  (13)

Thus,

$$[-\sin \theta \quad \cos \theta \quad x_{irc}] \cdot [\dot{X} \quad \dot{Y} \quad \dot{\theta}]^T = 0$$

Or,  $A(q) \cdot \dot{q} = 0$  (14)

The kinematic equation of the robot is obtained:  $\dot{q} = S(q) \cdot \eta$  (15)

Where S is the following matrix

$$S(q) = \begin{bmatrix} \cos \theta & x_{irc} \sin \theta \\ \sin \theta & -x_{irc} \cos \theta \\ 0 & 1 \end{bmatrix} \quad (16)$$

which satisfies  $S^T(q) \cdot A^T(q) = 0$  (17)

### 3.2 Dynamic model

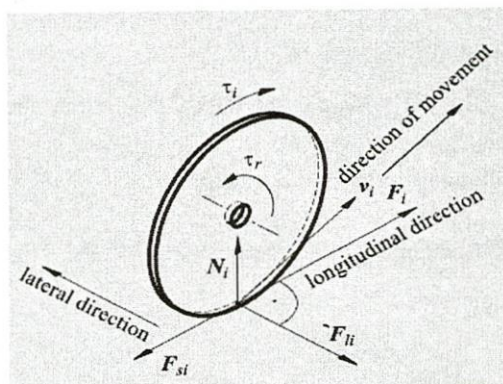

Fig. 6. The forces acting on one wheel.

Wheel forces are depicted in Fig.6

$$F_i = \frac{\tau_i}{r} \quad (18)$$

The active force is obtained

Neglecting additional dynamic properties, we obtain the following equation of equilibrium:

$$\begin{aligned} N_1 \cdot a &= N_2 \cdot b \\ N_4 \cdot a &= N_3 \cdot b \\ \sum_{i=1}^4 N_i &= mg \end{aligned} \quad (19)$$

Where m denotes the robot mass and g is the gravity acceleration. Using the symmetry along the longitudinal midline, we obtain

$$\begin{cases} N_1 = N_4 = \frac{b}{2(a+b)} mg \\ N_2 = N_3 = \frac{a}{2(a+b)} mg \end{cases} \quad (20)$$

The friction acting one wheel is obtained:

$$F_f(\sigma) = \mu_c \cdot N \cdot \text{sgn}(\sigma) + \mu_v(\sigma) \quad (21)$$

Where  $\sigma$  denotes the linear velocity.

N is force perpendicular to the surface.

$\mu_c, \mu_v$  are respectively the coefficients Coulumb and viscous friction.

In the dynamic model of this robot, the following relation is valid:  $\mu_c N \gg |\mu_v \cdot \sigma|$ .

Consequently, the term  $\mu_v \cdot \sigma$  can be neglected.

The following function is considered to approximate the function

$$\text{sgn}(\sigma) \cdot \hat{\text{sgn}}(\sigma) = \frac{2}{\pi} \arctan(k_s \cdot \sigma)$$

where the constant  $k_s$  satisfies the relations:  $k_s \gg 1$  and

$$\lim_{k_s \rightarrow \infty} \frac{2}{\pi} \cdot \arctan(k_s \cdot \sigma) = \text{sgn}(\sigma) \quad (22)$$

Applying to the skid steering robot, the force friction for one wheel can be written as:

$$F_{li} = \mu_{lci} \cdot mg \cdot \hat{\text{sgn}}(v_{yi}) \quad (23)$$

$$F_{si} = \mu_{sci} \cdot mg \cdot \hat{\text{sgn}}(v_{xi}) \quad (24)$$

where  $\mu_{lci}$  and  $\mu_{sci}$  denote respectively the coefficients of the lateral and longitudinal forces.

It is assumed that the potential energy of the robot  $\Pi = 0$  because of the planar motion. Neglecting the energy of rotating wheels, the kinetic energy of this robot can be rewritten:

$$T = \frac{1}{2} m (\dot{X}^2 + \dot{Y}^2) + \frac{1}{2} I \cdot \dot{\theta}^2 \quad (25)$$

$$\frac{d}{dt} \left( \frac{\partial T}{\partial \dot{q}} \right) = \begin{bmatrix} m \ddot{X} \\ m \ddot{Y} \\ I \ddot{\theta} \end{bmatrix} = M \cdot \ddot{q} \quad (26)$$

Hence,

$$M = \begin{bmatrix} m & 0 & 0 \\ 0 & m & 0 \\ 0 & 0 & I \end{bmatrix} \quad (27)$$

Where,

Considering the forces causing the dissipation of energy:

$$F_{rx}(\dot{q}) = \cos \theta \cdot \sum_{i=1}^4 F_{si}(v_{xi}) - \sin \theta \cdot \sum_{i=1}^4 F_{li}(v_{yi}) \quad (28)$$

$$F_{ry}(\dot{q}) = \sin \theta \cdot \sum_{i=1}^4 F_{si}(v_{xi}) + \cos \theta \cdot \sum_{i=1}^4 F_{li}(v_{yi}) \quad (29)$$

The resistant of moment around the center of mass can be obtained as

$$M_r(\dot{q}) = -a[F_{l1}(v_{y1}) + F_{l4}(v_{y4})] + b[F_{l2}(v_{y2}) + F_{l3}(v_{y3})] + c[-F_{s1}(v_{x1}) - F_{s2}(v_{x2}) + F_{s3}(v_{x3}) + F_{s4}(v_{x4})]$$

Letting

$$R(\dot{q}) = [F_{rx}(\dot{q}) \quad F_{ry}(\dot{q}) \quad M_x(\dot{q})]^T \quad (30)$$

Consequently, the active force generated by actuators can be calculated in the inertial frame as follow:

$$F_x = \cos \theta \cdot \sum_{i=1}^4 F_i$$

$$F_y = \sin \theta \cdot \sum_{i=1}^4 F_i \quad (31)$$

The active torque around the center of mass is obtained:

$$M' = c(-F_1 - F_2 + F_3 + F_4) \quad (32)$$

The vector of active forces has the following form:  $F = [F_x \quad F_y \quad M']^T$



Using (18), (31), (32), we get:

$$F = \frac{1}{r} \begin{bmatrix} \cos \theta \cdot \sum_{i=1}^4 \tau_i \\ \sin \theta \cdot \sum_{i=1}^4 \tau_i \\ c(-\tau_1 - \tau_2 + \tau_3 + \tau_4) \end{bmatrix} \quad (33)$$

The term  $\tau$  is defined by:

$$\tau = \begin{bmatrix} \tau_1 + \tau_2 \\ \tau_3 + \tau_4 \end{bmatrix} \quad (34)$$

$$B(q) = \frac{1}{r} \begin{bmatrix} \cos \theta & \cos \theta \\ \sin \theta & \sin \theta \\ -c & c \end{bmatrix} \quad (35)$$

We have:  $F = B(q) \cdot \tau$  (36)

Using (26), (30), (36), and equation's Lagrange we get:

$$M(q) \cdot \ddot{q} + R(\dot{q}) = B(q) \cdot \tau \quad (37)$$

Eq. (37) describes only the dynamic of a free body and does not include the nonholonomic constraint (14). Therefore, the constraint has to be imposed on (37). To solve this problem, a vector of Lagrange multiplier  $\lambda$  is considered [2], and (37) becomes as following equation:

$$M(q) \cdot \ddot{q} + R(\dot{q}) = B(q) \cdot \tau + A^T(q) \cdot \lambda \quad (38)$$

Multiplying from the left side by  $S^T(q)$ , and simplifying by using eq. (15), and the following equation,

$$\ddot{q} = \dot{S}(q) \cdot \eta + S(q) \cdot \dot{\eta} \quad (39)$$

we obtain:  $\overline{M} \cdot \dot{\eta} + \overline{C} \cdot \eta + \overline{R} = \overline{B} \cdot \tau$  (40)

Where,

$$\overline{C} = S^T M \dot{S} = m \cdot x_{irc} \begin{bmatrix} 0 & \dot{\theta} \\ -\dot{\theta} & \dot{x}_{irc} \end{bmatrix} \quad (41)$$

$$\overline{M} = S^T M S = \begin{bmatrix} m & 0 \\ 0 & m \cdot x_{irc}^2 + I \end{bmatrix} \quad (42)$$

$$\overline{R} = S^T R = \begin{bmatrix} F_{rx}(\dot{q}) \\ x_{irc} \cdot F_{ry}(\dot{q}) + M_r \end{bmatrix} \quad (43)$$

$$\overline{B} = S^T B = \frac{1}{r} \begin{bmatrix} 1 & 1 \\ -c & c \end{bmatrix} \quad (44)$$

## 4. CONTROL LAW

### 4.1 Operational Constraint

Let  $x_o$  be an arbitrary constant which sacrifices:  $x_o \in (-a, b)$

The constraint equation (13) is rewritten as:

$$v_y + x_o \cdot \dot{\theta} = 0 \quad (45)$$

Let S be a 3x2 dimensional matrix which sacrifices the equation (17)

$$S(q) = \begin{bmatrix} \cos \theta & x_o \cdot \sin \theta \\ \sin \theta & -x_o \cdot \cos \theta \\ 0 & 1 \end{bmatrix} \quad (46)$$

### 4.2 Control Algorithm

Let k be the state space vector

$$k = [X \quad Y \quad \theta \quad v_x \quad \omega] \quad (47)$$

To simplify the formula (15), (40), the matrix

$$f_2 = \overline{M}^{-1} (-\overline{C} \cdot \eta - \overline{R}) \quad (48)$$

is introduced, where

$$\bar{C} = S^T M \dot{S} = m \cdot x_0 \begin{bmatrix} 0 & \dot{\theta} \\ -\dot{\theta} & \dot{x}_0 \end{bmatrix} \quad (49)$$

$$\bar{M} = S^T M S = \begin{bmatrix} m & 0 \\ 0 & m \cdot x_0^2 + I \end{bmatrix} \quad (50)$$

$$\bar{R} = S^T R = \begin{bmatrix} F_{rx}(\dot{q}) \\ x_0 \cdot F_{ry}(\dot{q}) + M_r \end{bmatrix} \quad (51)$$

$$\bar{B} = S^T B = \frac{1}{r} \begin{bmatrix} 1 & 1 \\ -c & c \end{bmatrix} \quad (52)$$

Combining (15) and (40), the kinematic equation and the dynamic equation are written:

$$\dot{k} = \begin{bmatrix} S \cdot \eta \\ f_2 \end{bmatrix} + \begin{bmatrix} 0 \\ \bar{M}^{-1} \cdot B \end{bmatrix} \cdot \tau \quad (53)$$

This state equation can be further simplified as:

$$\dot{k} = \begin{bmatrix} S \cdot \eta \\ 0 \end{bmatrix} + \begin{bmatrix} 0 \\ I \end{bmatrix} \cdot u \quad (54)$$

$$\tau = (\bar{M} \cdot \bar{B}^{-1})(u - f_2) \quad (55)$$

Let a reference point be denoted in the local inertial frame by  $(x_r^c, y_r^c)$ . The robot is controlled so that the reference point tracks the given trajectory.

The world coordinates of the reference point are obtained as:

$$\begin{cases} X_r = X_c + x_r^c \cdot \cos \theta - y_r^c \cdot \sin \theta \\ Y_r = X_c + x_r^c \sin \theta + y_r^c \cos \theta \end{cases} \quad (56)$$

The output equation is obtained:

$$y = h(q) = [X_r \quad Y_r]^T \quad (57)$$

$$\dot{y} = \left( \frac{\partial h(q)}{\partial q} \right) \cdot \dot{q} = \Phi \cdot \eta \quad (58)$$

where

$$\Phi = \begin{bmatrix} \cos \theta & x_o \sin \theta - x_r^c \sin \theta - y_r^c \cos \theta \\ \sin \theta & -x_o \cos \theta + x_r^c \cos \theta - y_r^c \sin \theta \end{bmatrix} \quad (59)$$

By taking  $x_o \neq x_r^c$ ,  $\Phi$  is regular.

From (58) we get:

$$\ddot{y} = \dot{\Phi} \cdot \eta + \Phi \cdot \dot{\eta} \quad (60)$$

Hence,

$$u = \Phi^{-1}(\eta - \dot{\Phi} \eta) \quad (61)$$

Let  $y^d$  be a desired trajectory, and  $e = y^d - y$  be a feedback error.

$$\ddot{y} = \eta = \ddot{y}^d + K_d(\dot{y}^d - \dot{y}) + K_p(y^d - y) \quad (62)$$

By using equations (54), (55), (61), (62), a new algorithm has been presented. It is easy to control the angular velocities of wheels in other that a skid steering robot tracks a given trajectory.

## 5. SIMULATION RESULTS

To validate the performance of the control algorithm, the motion of skid steering mobile robot is simulated by Matlab. The robot is designed to track a given trajectory. The advantage of the algorithm is the angular velocity of each wheel can be determined without the inertia moment and the mass of the robot. Therefore, dynamic parameters aren't considered for simplicity. The dimensions' robot are chosen as  $a = b = c = 1(m)$ . The robot starts at location (-3; 8) with the



angle  $\theta = \frac{\pi}{2}$ , the horizontal velocity  $v_x = 0$ , and the angular velocity  $\omega = 0$ . The reference point is the center of mass  $x_r^c = y_r^c = 0$ . The constant  $x_o$  is chosen as follow  $x_o = 3.2(m)$

Case 1: A desired trajectory is given by:

$$\begin{cases} x = 4 * t & (m) \\ y = 2 * t & (m) \end{cases}$$

The controller parameters are chosen as follow:  $k_p = 52, k_D = 15$

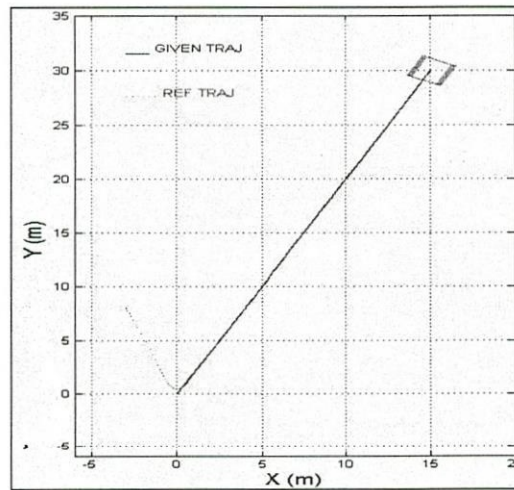

(a)

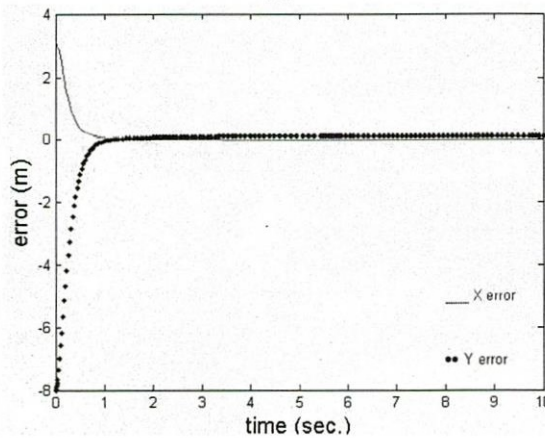

(b)

Fig. 7 The simulation result of case 1. (a) robot trajectory, and (b) tracking error.

Figure 7(a) shows the reference trajectory, and figure 7(b) shows the tracking error in the fixed frame. It is clearly seen from the plots that the reference point's trajectory (robot

trajectory) quickly converges to the given trajectory (desired trajectory).

Case 2: A desired trajectory is given by:

$$\begin{cases} x = 7 \sin(t) & (m) \\ y = 7(1 - \cos(t)) & (m) \end{cases}$$

The controller parameters are chosen as follow:  $k_p = 10, k_D = 5$

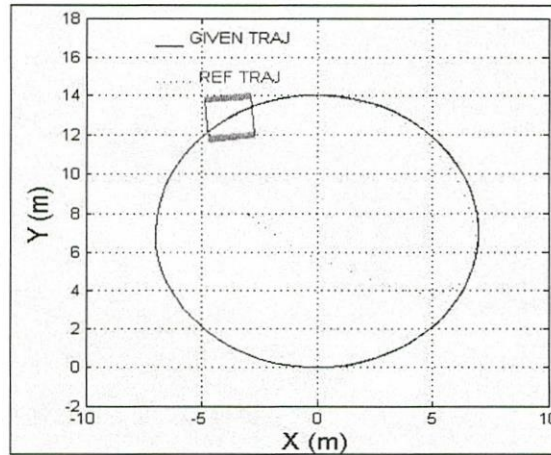

(a)

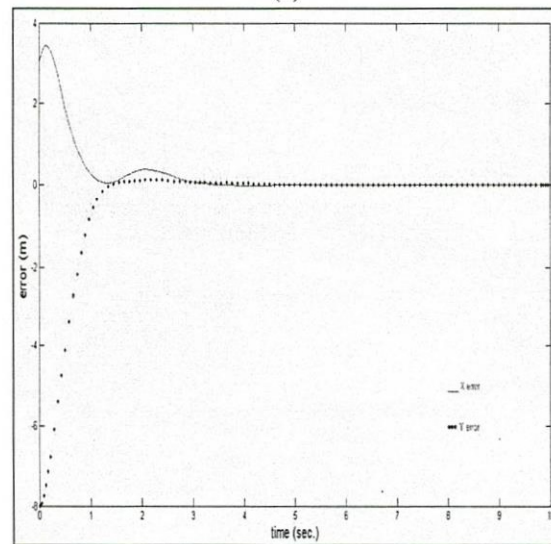

(b)

Fig. 8 The simulation result of case 2. (a) robot trajectory, and (b) tracking error.

Similarly, the reference point's trajectory quickly converges to the given trajectory.

## 6. CONCLUSION

In this paper, a new algorithm of trajectory tracking control for 4-wheel skid steering mobile robot is presented. The output equation is chosen to be the coordinates of the reference

point fixing in the robot. Because the mobile robot is subject to nonholonomic constraints, dynamics system is nonlinear (see eq. 40). However, the number of output coordinates equals the number of input commands. Thus, one can use nonlinear state feedback law in order to transform the nonlinear robot kinematics, dynamics into a linear system. The

effectiveness of this algorithm is validated by simulations on two different trajectories.

In the future, we will integrate this algorithm with stepper motor control to design

completely a skid steering mobile robot as well as apply a Lyapunov stability analysis to guarantee the stability of this controller.

## ĐIỀU KHIỂN THEO QUỹ ĐẠO MỘT RÔBỐT DI ĐỘNG LÁI TRƯỢT 4 BÁNH

Đặng Văn Nghìn<sup>(1)</sup>, Nguyễn Văn Quốc Khánh<sup>(2)</sup>

(1) Viện Cơ Tin học Tp.HCM

(2) Trường Đại học Bách Khoa, ĐHQG-HCM

**TÓM TẮT:** Bằng cách áp dụng ràng buộc nonholonomic và phương trình Lagrange cho hệ thống nonholonomic, một phương pháp được đưa ra để mô hình và điều khiển robot di động lái trượt 4 bánh chạy theo quỹ đạo cho trước. Đầu tiên, các cơ sở của hệ thống nonholonomic được giới thiệu. Tiếp theo, mô hình động học và động lực học của robot lái trượt được khảo sát. Để điều khiển robot dò theo quỹ đạo, một giải thuật mới được đưa ra bằng cách ứng dụng tuyến tính hóa hồi tiếp và bộ điều khiển PD. Hơn nữa, kết quả mô phỏng đã chứng tỏ tính hiệu quả của thuật toán.

**Từ khóa:** sự điều khiển đồng chỉnh, robot lái trượt, ràng buộc nonholonomic.

### REFERENCES

- [1]. Lakkad S.: *Modeling and simulation of steering systems for autonomous vehicle*, MSc thesis, the Florida state university, (2004).
- [2]. Caracciolo L., De Luca A. and Iannitti S.: *Trajectory tracking control of a four-wheel differentially driven mobile robot*. — *IEEE Int. Conf. Robotics and Automation*, Detroit, MI, pp. 2632–2638, (1999).
- [3]. Dixon W.E., Behal A., Dawson D.M. and Nagarkatti S.P. *Nonlinear Control of Engineering Systems, A Lyapunov-Based Approach*. — Boston: Birkhäuser. (2003)
- [4]. Dixon W.E., Dawson D.M., Zergeroglu E. and Behal A. *Nonlinear Control of Wheeled Mobile Robots*. — London:Springer. (2001)
- [5]. Yoshio Yamamoto and Xiaoping Yun, *Coordinating Locomotion and Manipulation of a Mobile Manipulator*. *IEEE Transactions on Automatic Control*, Vol. 39, No. 6, pp. 1326-1332. (1994)
- [6]. K. Kozłowski, D. Pazderski, *Modeling and control of a 4-wheel skid-steering mobile robot*. *Int. J. Appl. Math. Comput. Sci*, Vol. 14, No. 4, 477–496, (2004).



- [7]. K. Kozłowski, D. Pazderski, I.Rudas, J.Tar, *Modeling and control of a 4-wheel skid-steering mobile robot*, From theory to practice, Poznan University of Technology, No. DS 93/121/04.
- [8]. R. Fierro and F. L. Lewis, *Control of a Nonholonomic Mobile Robot*, Backstepping Kinematics into Dynamics, Journal of Robotic Systems 14(3), pp.149–163, (1997).