

COMPUTE AND DEFINE EXACTLY THE REGION OF ELASTIC REACTION FORCE FOR CALCULATING THE SECTION FORCE OF UNDERGROUND CONSTRUCTION BY FINITE ELEMENT METHOD

Nguyen Quoc Tuyen, Le Van Nam
University of Technology, VNU-HCM

(Manuscript Received on September 26th, 2007, Manuscript Revised March 03rd, 2008)

ABSTRACT: *Defining the region which effected by the elastic reaction force of underground construction had the important meaning for the calculation of underground structure's section force. The effective of elastic reaction force makes slight the working of underground structure, controlling their deformation, increasing numeric value of axial force and decrease the value of bending moment of structure. For the previous time, by the experiment calculation, the angle which define the region had not effected by the elastic reaction force of ground foundation is: $\varphi_0 = \pi/4$. In this research, we build the code of Matlab programme to compute the underground construction by Finite element method, making a iterative calculation to define the φ_0 angle with the purpose to define exactly the region of elastic reaction force of underground structure, at the same time, making a computation of section force value of the underground structure.*

1. THE OUTLINE OF COMPUTING THE UNDERGROUND CONSTRUCTION BY THE METHOD OF REPLACING TO BAR SYSTEM

Tunnel shell works along surround the elastic environment, which is considered as the super static system with high grade and complex. The computation of this system in general case: tunnel shell has many type of shape forms, the tunnel shell's thickness is changed by in fact working condition, and we can not show these factor in fact for calculation. Therefore, to define the section forces, we can use the approximate method, called: the method of replacing to bar system.

Principles of this method:

- Replacing the continuous curve of tunnel shell's structure by polygonal line segment.
- Each line segment's stiffness (EF) is considered as constant.
- Replacing the distribute load of stratum pressure q and p by the concentrate load at nodes at point of polygonals. The tunnel shell's seft weight is also replaced by concentrate load at the beginning and end point of bar.
- The elastic environment is replaced by elastic bearings setting at point of polygonals which direct to curve's radius.

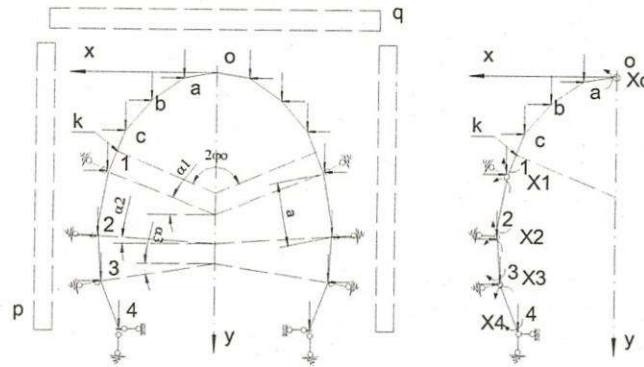

Figure 1. The elastic foundation model

2. THE ELEMENT STIFFNESS MATRIX

The most basic point in solving the underground structure problem by finite element method is building the element stiffness matrix. Then assembling the element equations based on the continuous conditions, the boundary conditions to make the system of equation and next step is solving this system of equation.

The beam element on elastic foundation:

Contains the modulus of elasticity E, the cross section area A, the moment of inertia I, the spring stiffness in the axial direction ka, and the spring stiffness in the transverse direction kt.

The matrix K_s^e is given by:

$$K_s^e = \frac{L}{420} \begin{bmatrix} 140k_a & 0 & 0 & 70k_a & 0 & 0 \\ 0 & 156k_t & 22k_tL & 0 & 54k_t & -13k_tL \\ 0 & 22k_tL & 4k_tL^2 & 0 & 13k_tL & -3k_tL^2 \\ 70k_a & 0 & 0 & 140k_a & 0 & 0 \\ 0 & 54k_t & 13k_tL & 0 & 156k_t & -22k_tL \\ 0 & -13k_tL & -3k_tL^2 & 0 & -22k_tL & 4k_tL^2 \end{bmatrix} \quad (1)$$

3. THE STIFFNESS MATRIX OF THE BEAM ON THE ELASTIC FOUNDATION IN THE SYSTEM OF THE GLOBAL CO-ORDINATE

In the above part, we presented the stiffness matrix with the system of local co-ordinate of element. When making the calculation we have to transform this matrix to the global co-ordinate.

Figure 2 presents the cant bar element with any angle β of horizontal axis \bar{x} . Displacement is presented by two system of co-ordinate: one deal with local co-ordinate of element by 3 displacements u, v, θ ; the second deal with the global co-ordinate $\bar{u}, \bar{v}, \bar{\theta}$.

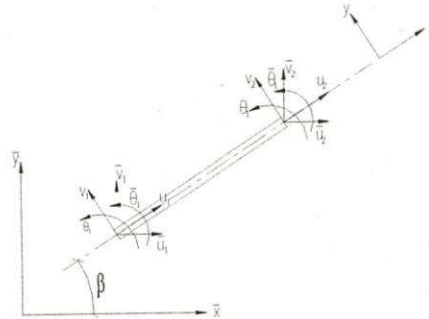

Figure 2. Beam in the global system

To present the element stiffness matrix from the local co-ordinate system to global co-ordinate system, we use the rotate vector, with the relation as follows:

$$\begin{Bmatrix} u_1 \\ v_1 \\ \theta_1 \\ u_2 \\ v_2 \\ \theta_2 \end{Bmatrix} = \begin{bmatrix} \cos\beta & -\sin\beta & 0 & 0 & 0 & 0 \\ -\sin\beta & \cos\beta & 0 & 0 & 0 & 0 \\ 0 & 0 & 1 & 0 & 0 & 0 \\ 0 & 0 & 0 & \cos\beta & -\sin\beta & 0 \\ 0 & 0 & 0 & -\sin\beta & \cos\beta & 0 \\ 0 & 0 & 0 & 0 & 0 & 1 \end{bmatrix} \begin{Bmatrix} \bar{u}_1 \\ \bar{v}_1 \\ \bar{\theta}_1 \\ \bar{u}_2 \\ \bar{v}_2 \\ \bar{\theta}_2 \end{Bmatrix} \quad (2)$$

3.1. The effective of elastic reaction force of ground foundation

The elastic resistance force arisen at surface of tunnel shell structure by arch or circular shape, except the “ peel region”, the region without displacement to the stratum : region a-b, region c-d : tunnel wall was increased the stability condition effected by the reactive elastic force. The b-c region had not that effect.

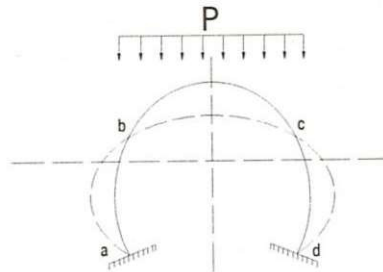

Figure 3. The deformation line

3.2. Define the load capacity

In the research of M.M.Protodiakonov, the vertical pressure of soil is affected to the tunnel structure caused by the weigh of mass stratum, which were undermined limit by the pressure of tunnel arch and the tunnel perimeter.

The arch equilibrium equation is the parapol grade 2 with span 2b and height hv:

$$y = \frac{x^2}{b \cdot f_{kc}}$$

In which:

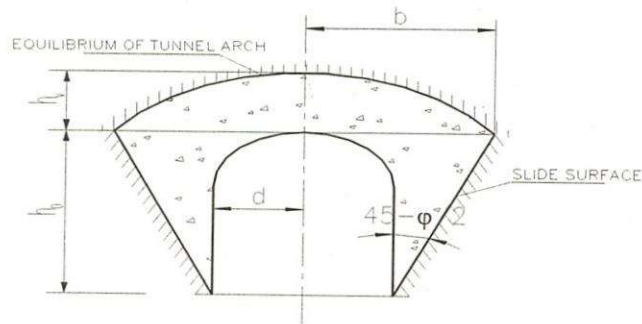

THE COLLAPSE DIAGRAM OF SOIL AROUND TUNNEL STRUCTURE

Figure 4. The collapse diagram of soil

b : a haft of span arch around tunnel structure

f_{kc} : strong coefficient

At that time, the pressure response with the horizontal axis x is defined by:

$$q(y) = \gamma(h_v - y) = \gamma \left(\frac{b}{f_{kc}} - \frac{x^2}{b \cdot f_{kc}} \right)$$

The part, which located on the slide state of both side is transmitted into the slide state to effect on two-wall side to create the horizontal pressure.

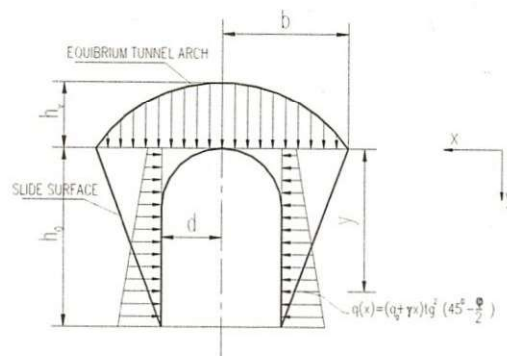

Figure 5. The computation diagram pressure

$$\Rightarrow q(x) = \gamma \left(\frac{b^3 - d^3}{(b - d)3b \cdot f_{kc}} + y \right) \text{tg}^2 \left(45^\circ - \frac{\varphi}{2} \right)$$

4.SOLVING THE PROBLEM

4.1.General problem

The underground construction has the dimension as figure 6. The design thickness average is 70cm which made by concrete M200 located inside the layer of gravelly soil with seltweight is 1.8 Ton/m^3 , strong coefficient refer to the appendix of M.M.Protodiakonov is $f_{kc} = 1.3$, the inner friction angle $\varphi=40^0$ with 2 foundation coefficient $k_a=10 \text{ T/m}^3$, $k_i=1\text{T/m}$. The problem makes the calculation for the section force occur to the structure, and determines the region which occurs the elastic reaction force.

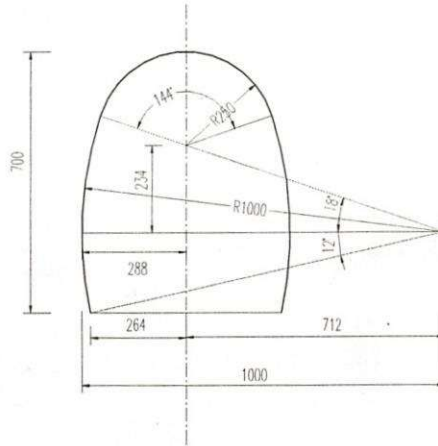

Figure 6. Tunnel cross section (in cm)

Load capacity effected to element:

Horizontal load (side pressure) Considering any element k:

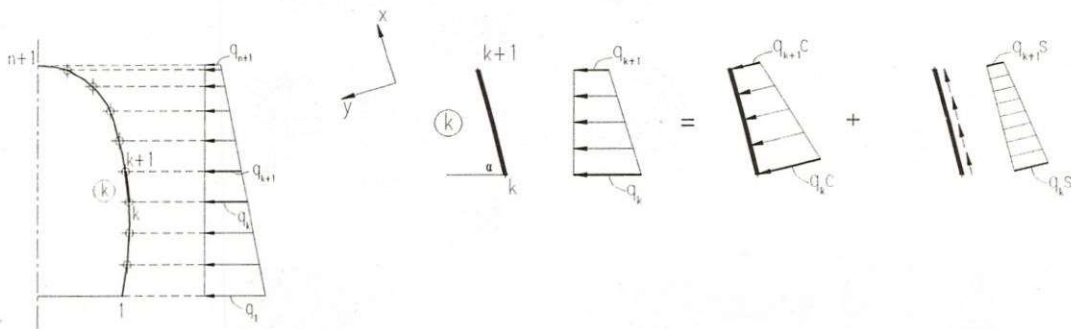

Figure 7. Divide element

The element affected load k is separated by 2 compositions with 2 directions of local coordinate of element. Performing equation of this load:

$$q(x)=x*qLx/L-(x-L)*q0x/L$$

$$q(y)=x*qLy/L-(x-L)*q0y/L$$

In which :

$$qLx=qk+l\sin\alpha; q0x=qk\sin\alpha; qLy=qk+l\cos\alpha; q0y=qk\cos\alpha$$

L : Element length

α : Angle, which fit by element axis and horizontal direction.

Therefore, 1 element is affected by 2 loads at the same time : perpendicular load with element axis and along axis load

5.PROGRAMMING CONTENT

Graphical sketch

The programming to compute the underground construction is presented by this graphical sketch:

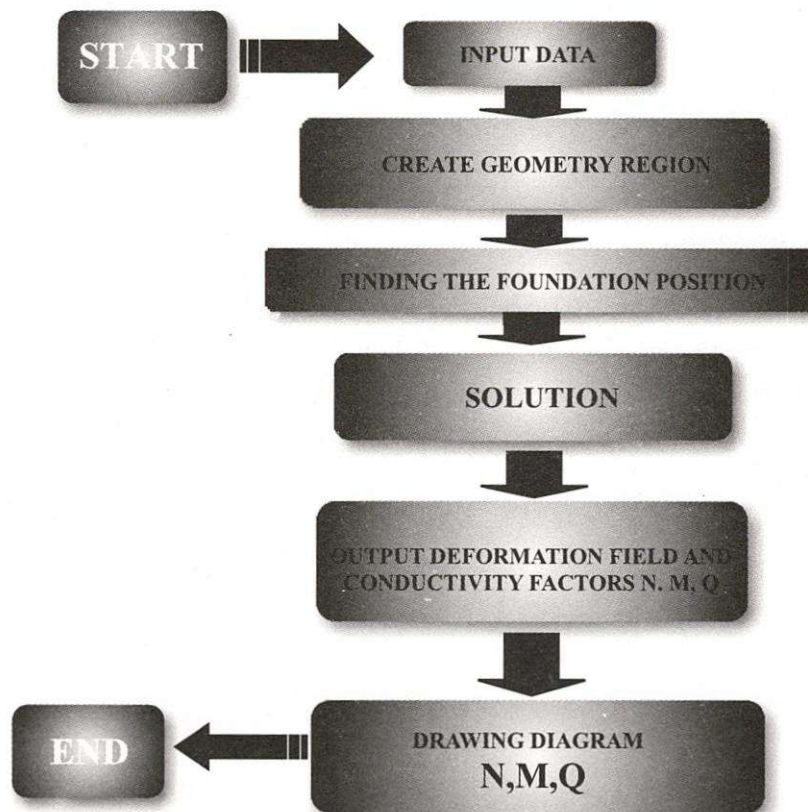

6.RESULT OF THE CALCULATION OF SECTION FORCE AND DEFINE THE REGION OF ELASTIC REACTION FORCE OF UNDERGROUND STRUCTURE

6.1.The receiving result of mesh 40 element : 30 elements beam on the elastic foundation, 10 elements of normal

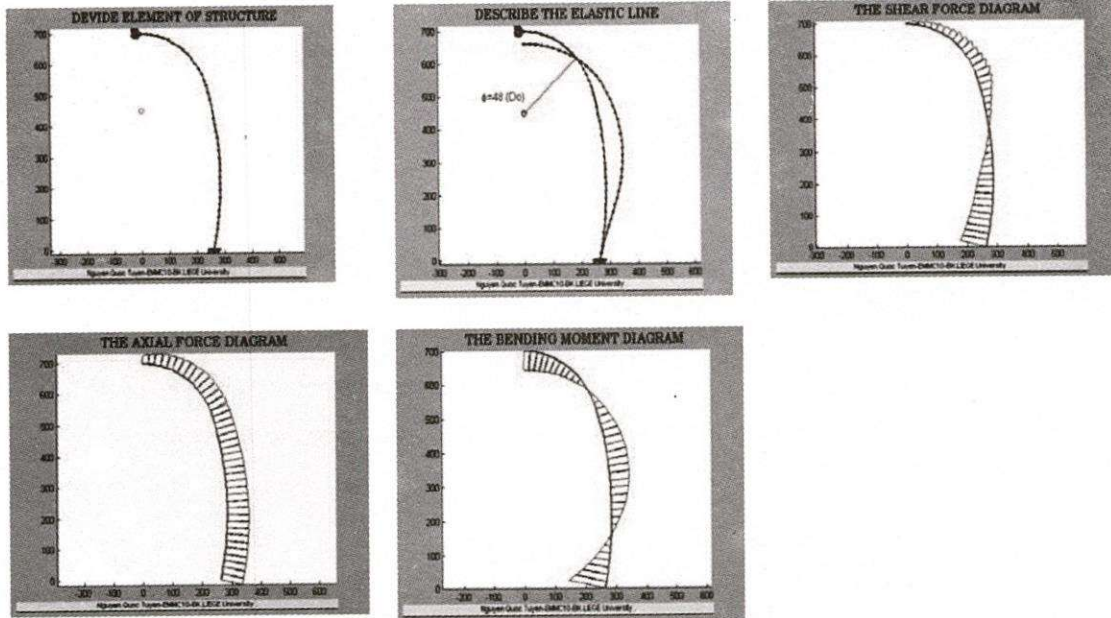

6.2.The receiving result of mesh 200 element : 154 elements beam on the elastic foundation, 46 elements of normal

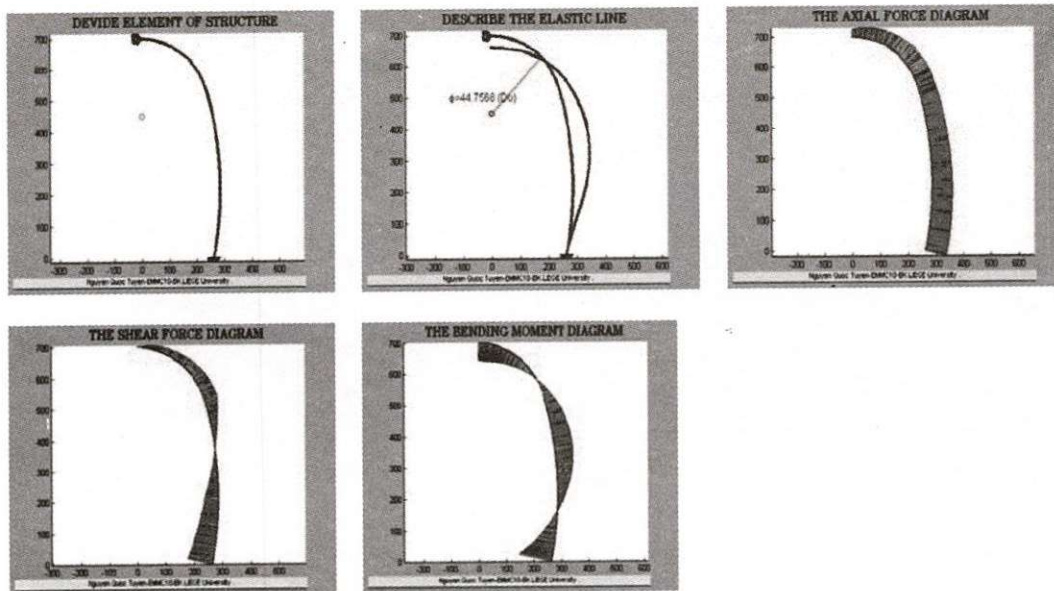

6.3. Evaluate the convergency of problem while define the region of elastic reaction force.

a) In order to make this comparison of the interdependent of angle u_0 , we consider and survey the changing cases of tunnel thickness, the grade of lining concrete.

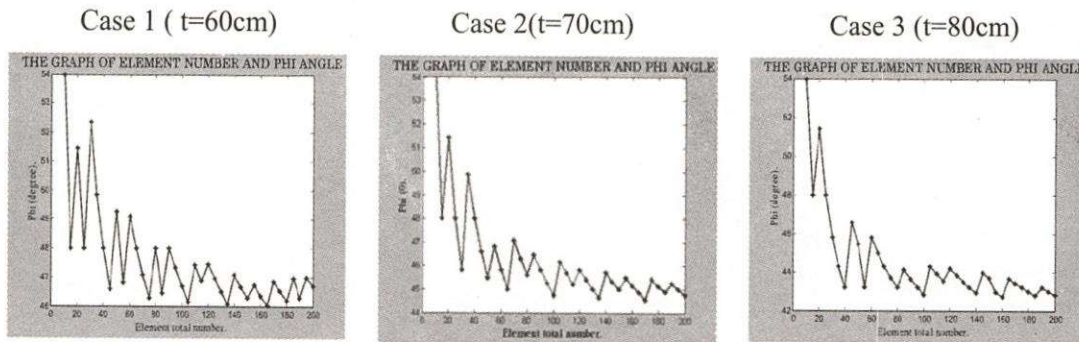
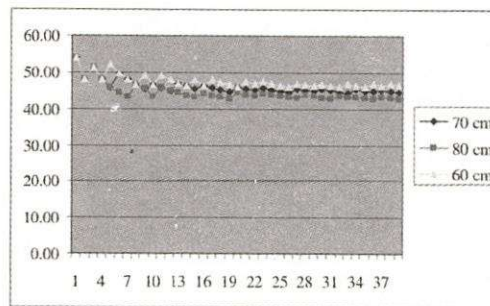

Figure 8. The convergence of angle u_0 to compare with the experiment value angle $u_0 = 45$

When the number of element increased, the angle u was advanced to the converge value ($u_0 = 44.760$ correlative with number of element is 200).



The relation between the tunnel thickness with the effected region by the elastic reaction force with angle u_0 :

Thickness (cm)	u_0 Analysis	u_0 Experiment	Error (%)
40	47.02	45	4.49
50	46.89	45	4.20
60	46.7	45	3.78
70	44.76	45	-0.53
80	42.81	45	-4.87
90	44.92	45	-0.18
100	45.59	45	1.31

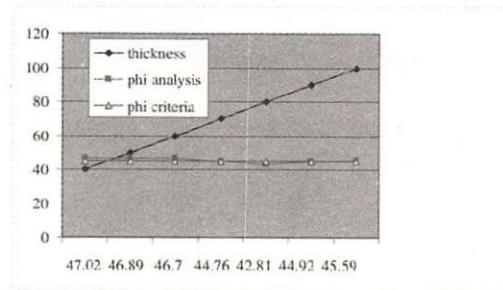

Figure 9. The relation of tunnel thickness and angle U_0

With several different thickness of tunnel shell, we can get the u_0 angle which advanced to the converge value around the acceptable region for standard calculation $\varphi_0 = \pi/4$. Therefore, with the experiment formula, we have the experience value of the effected region by the elastic reaction force $\varphi_0 = \pi/4$ to calculate the underground construction, so we can accept this experiment value.

b) Compare to the relation between of grade of concrete and the effected region by the elastic reaction force with u_0 angle, which consider to the changing of tunnel shell's thickness:

Grade of Concrete		T=60cm	T=70cm	T=80cm
M	E (Kg/cm ²)	U_0	U_0	U_0
M150	2.10E+05	46.702	44.756	42.8108
M200	2.40E+05	46.772	44.7567	42.8280
M250	2.65E+05	46.911	44.6567	42.7759
M300	2.90E+05	46.875	44.4567	42.7128
M350	3.10E+05	46.885	44.9567	42.9125

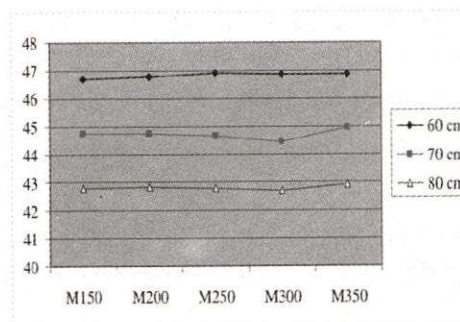

Figure 10. The relation of tunnel shell thickness, grade of concrete and angle u_0

7.CONCLUSION

Our research programme is general for underground's structure calculation, we can use to solve for some other underground construction problems. With these Matlab programme-code, we can develop, upgrade to get the designed modem, which can be used in calculating of underground construction problems.

By the result of our research, we can recognize that the region which is affected by the elastic reaction force to underground's structure, represented by the u_0 angle, is not changed by the changing of the grade of concrete, but depending on the changing of tunnel shell's thickness.

We can define exactly the angle u_0 by our research programme, and this result also shows the suitable of the experiment formula when we use the experienced-angle $\varphi_0 = \pi/4$ to define the elastic reaction force for computation the underground construction. So, by this Matlab programme code, we can establish the reference table of angle u_0 which has the value exactly depending to the data of foundation. It will be the useful data in teaching curriculum and in designing of underground construction.

TÍNH TOÁN VÀ XÁC ĐỊNH CHÍNH XÁC VÙNG CHỊU LỰC KHÁNG ĐÀN HỒI TRONG VIỆC TÍNH TOÁN NỘI LỰC CÔNG TRÌNH NGẦM

Nguyễn Quốc Tuyên, Lê Văn Nam
Trường Đại Học Bách Khoa, ĐHQG - HCM

TÓM TẮT: Việc xác định vùng phát sinh chịu lực kháng đàn hồi của công trình ngầm đặt trong các vùng đất nền có ý nghĩa quan trọng trong việc tính toán nội lực kết cấu công trình ngầm. Lực kháng đàn hồi của đất nền có vai trò làm ổn định và giảm nhẹ sự làm việc thực của kết cấu ngầm, đồng thời làm tăng trị số lực dọc và làm giảm giá trị momen uốn của kết cấu. Trước đây theo các công thức tính toán thực nghiệm, góc xác định vùng không chịu ảnh hưởng lực kháng đàn hồi của đất nền được lấy là: $\varphi_0 = \pi/4$. Trong bài báo nghiên cứu của mình, tôi xin trình bày phần tính toán kết cấu công trình ngầm bằng phương pháp phần tử hữu hạn, tính toán lặp để tìm được giá trị chính xác của góc φ_0 nhằm mục đích xác định chính xác vùng phát sinh chịu lực kháng đàn hồi của kết cấu ngầm, đồng thời từ đó tính toán các giá trị nội lực trong kết cấu công trình ngầm.)

REFERENCES

- [1]. C.S.Krishnamoorthy, *Finite Element Analysis Theory and Programming*, Second Edition, Tata McGraw-Hill Publish Company Limited, New Delhi, (1996).
- [2]. Nguyen Hoai Son, Vu Phan Thien, *The Finite Element Method with Matlab*, Publishing Company of Ho Chi Minh city National University, (2001).
- [3]. Tran Thanh Giam, Ta Tien Dat, *Compute and Design underground construction*, Construction Publishing Company, (2002).
- [4]. Heinz Duddeck, *Guidelines for the Design of Tunnel*, Volume 3, 1988, ITA Working Group on General Approaches in Design of Tunnels.
- [5]. Huynh Thi Minh Tam, University of Technology at Ho Chi Minh City, Master Thesis with topic: *Studying of underground structure*, (2001-2003).
- [6]. Nguyen The Phung, Nguyen Quoc Hung, *Design the traffic tunnel construction*, Traffic and Transportation Publishing Company, (1998).
- [7]. David M.Potts and Lidija Zdravkovic, Application: *Finite element analysis geological engineering*, Thomas Telford Publishing, Thomas Telford Ltd, I.Heron Quay, London, (2001).